

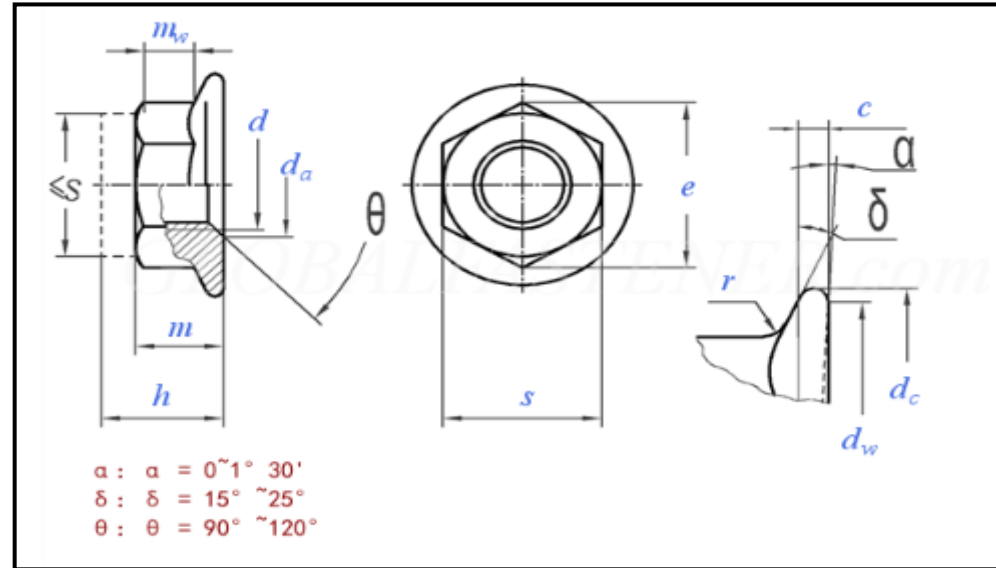

nufast Ltd.

PRODUCTION DRAWING

PREVAILING TORQUE NON-METALLIC INSERT HEXAGON NUT WITH FLANGE COMPLIANT TO DIN 6926



SIZE d	PITCH	s		e	c	d _a		d _w	d _c	m	m _w	r	h	
		Min.	Max.	Min.	Min.	Min.	Max.	Min.	Min.	Min.	Min.	Max.	Min.	Max.
M5	0.80	7.78	8.00	8.79	1.00	5.00	5.75	9.80	11.80	4.70	2.20	0.30	6.74	7.10
M6	1.00	9.78	10.00	11.05	1.10	6.00	6.75	12.20	14.20	5.70	3.10	0.36	8.74	9.10
M8	1.25	12.73	13.00	14.38	1.20	8.00	8.75	15.80	17.90	7.60	4.50	0.48	10.67	11.10
M10	1.50	14.73	15.00	16.64	1.50	10.00	10.80	19.60	21.80	9.60	5.50	0.60	13.07	13.50
M12	1.75	17.73	18.00	20.03	1.80	12.00	13.00	23.80	26.00	11.60	6.70	0.72	15.67	16.10
M14	2.00	20.67	21.00	23.36	2.10	14.00	15.10	27.60	29.90	13.30	7.80	0.88	17.68	18.20
M16	2.00	23.67	24.00	26.75	2.40	16.00	17.30	31.90	34.50	15.30	9.00	0.96	19.46	20.30
M20	2.50	29.16	30.00	32.95	3.00	20.00	21.60	39.90	42.80	18.90	11.10	1.20	23.96	24.80

PROOF LOAD - TEST REQUIREMENTS
ISO 898 / 2: 1992

SCREW A HARDENED MANDREL INTO THE TEST WELDNUT ENSURING THAT A MINIMUM THREE FULL THREADS ARE PROJECTING OUT OF THE NUT. LOAD AS ABOVE TO BE APPLIED FOR 15 SECONDS. THE LOAD STATED IS A MINIMUM LOAD AND MUST BE ACHIEVED. AFTER A SUCCESSFUL TEST THE MANDREL MUST BE CAPABLE OF REMOVAL BY FINGER TURN, AN INITIAL HALF TURN BY WRENCH IF REQUIRED IS PERMISSIBLE.

EXTRACT FROM DIN 6926—1983

FORMAT TO SYSTEM 25/06/2014 AMMENDMENTS

NUFAST PART NUMBER

DIN 6926